

NOTICE DE POSE – ACCESSOIRES
KIT SERRURE 2PTS SECTIONNELLE

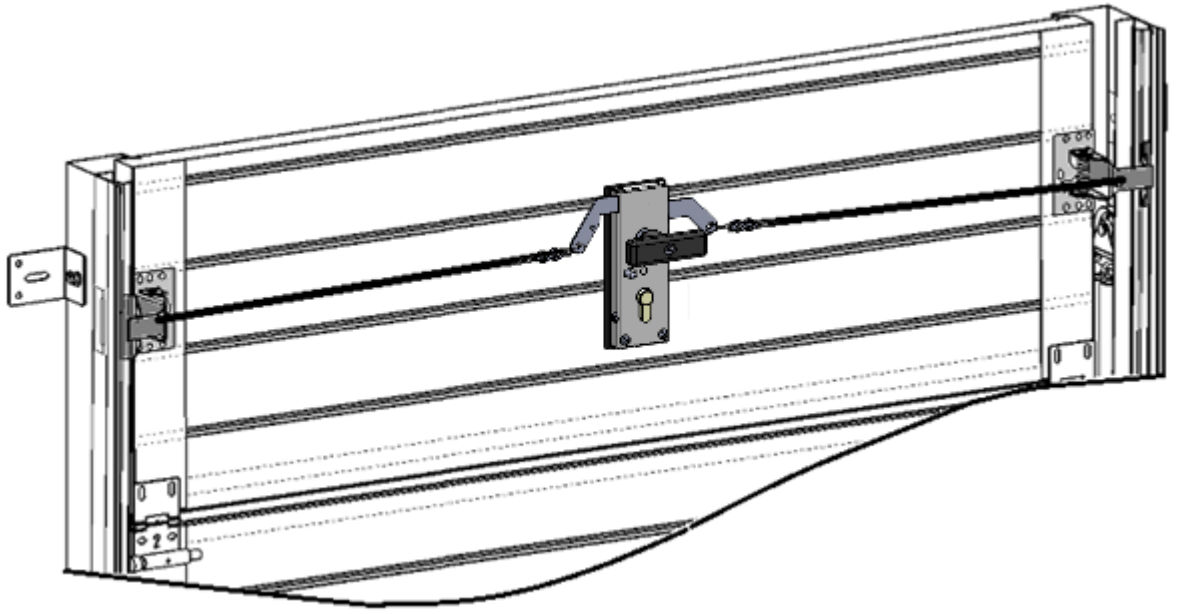

Illustrations non contractuelles



Scie cloche Ø20

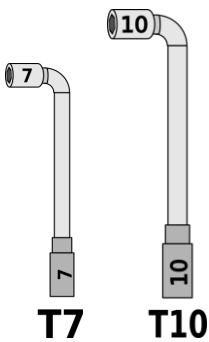





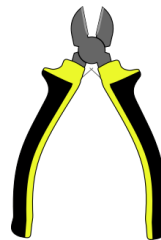

T7

T10

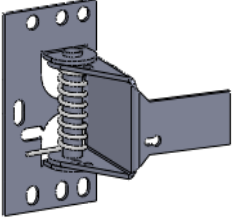
Tournevis Cruciforme PZ2

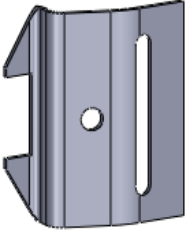
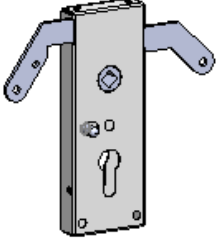

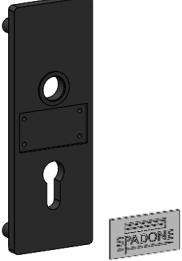
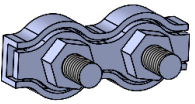
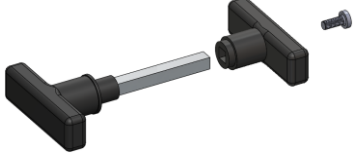
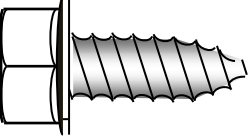
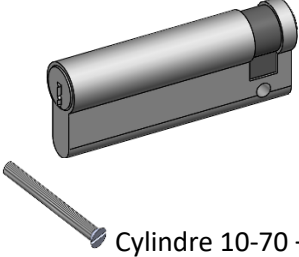
CONTENU CARTON ACCESSOIRES

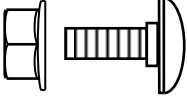
 <p>Autolatch</p>	<p>2x</p>		 <p>Contre cadre coffre de serrure</p>	<p>1x</p>
 <p>Gache pour autolatch</p>	<p>2x</p>		 <p>Coffre à double sorties Type H</p>	<p>1x</p>
 <p>Cable 1.5mm + 2 plombs à sertir</p>	<p>5m</p>		 <p>Plaque de propreté PVC + logo SPADONE à clipper</p>	<p>1x</p>
 <p>Serre câble</p>	<p>2x</p>		 <p>Poignée P. Fixe PVC noire Carré L85 + vis M6x15</p>	<p>1x</p>
 <p>Vis à tôle 6.3x15</p>	<p>8x</p>		 <p>Cylindre 10-70 + vis</p>	<p>1x</p>
 <p>Vis 5x60</p>	<p>2x</p>			
 <p>Boulon poêlier M6</p>	<p>4x</p>			

160

145

60

44

$\varnothing 15$

$\varnothing 10$

$\varnothing 10$

$\varnothing 20$

$\varnothing 20$

$\varnothing 10$

$\varnothing 10$

60



Vérifier la bonne échelle de l'impression

GABARIT DE PERCAGES

Impression au format A5

① PERCER LE PANNEAU

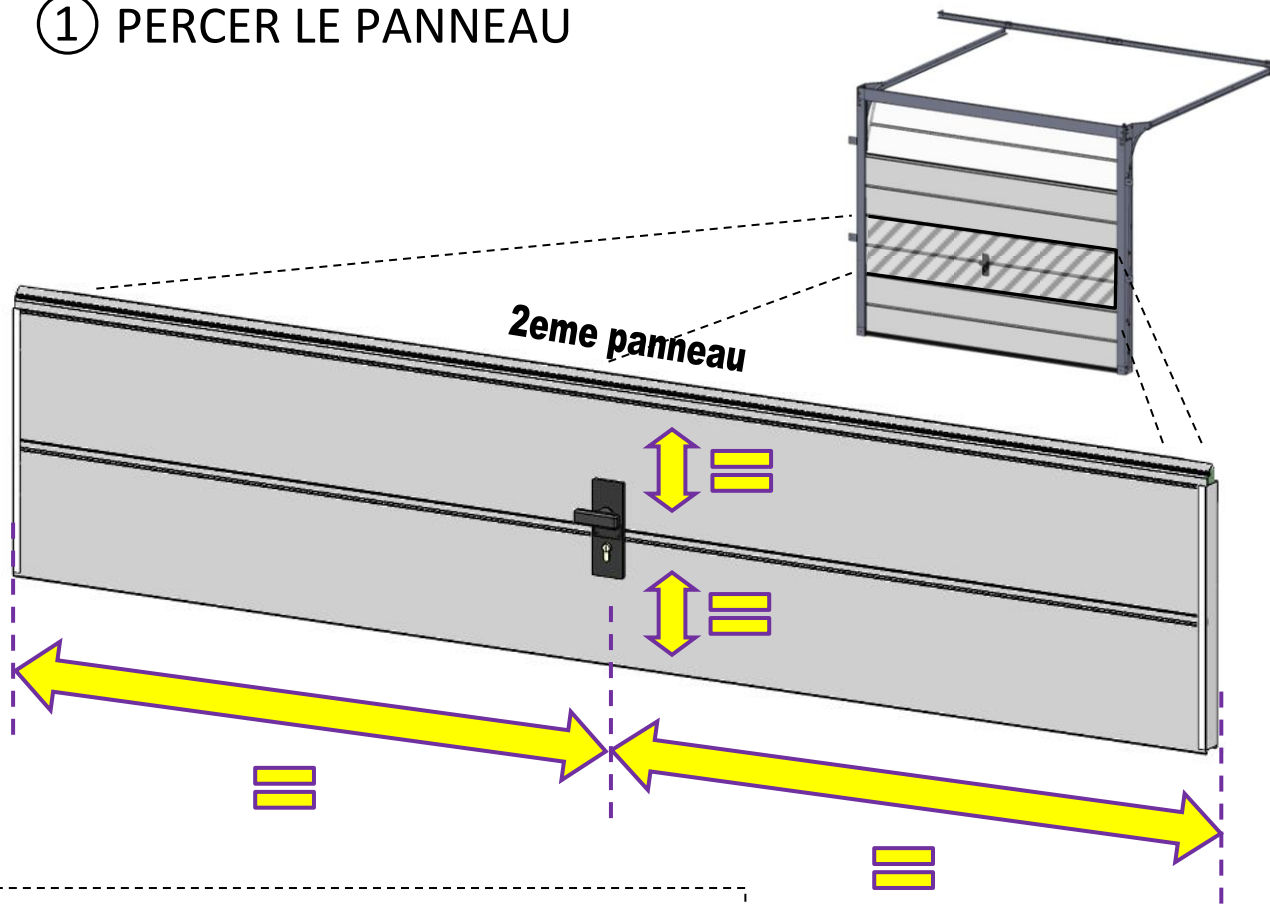

① Sur le 2^{ème} panneau : **tracer** avec un marqueur le repère de la position de la poignée (vue de l'extérieur)

② Présenter la poignée + la plaque de propreté pour un contrôle visuel

③ A l'aide du **gabarit page 2**, percer le panneau (Scie cloche de 20mm + foret de 10mm)

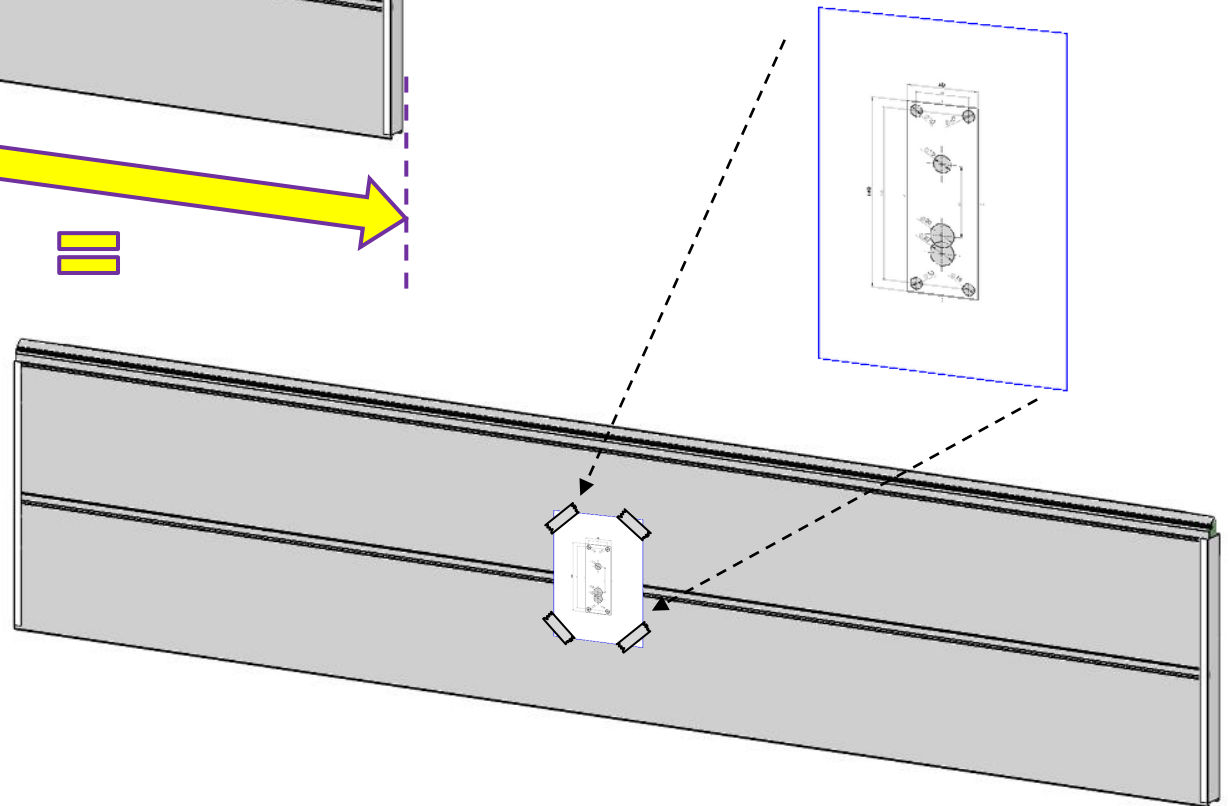
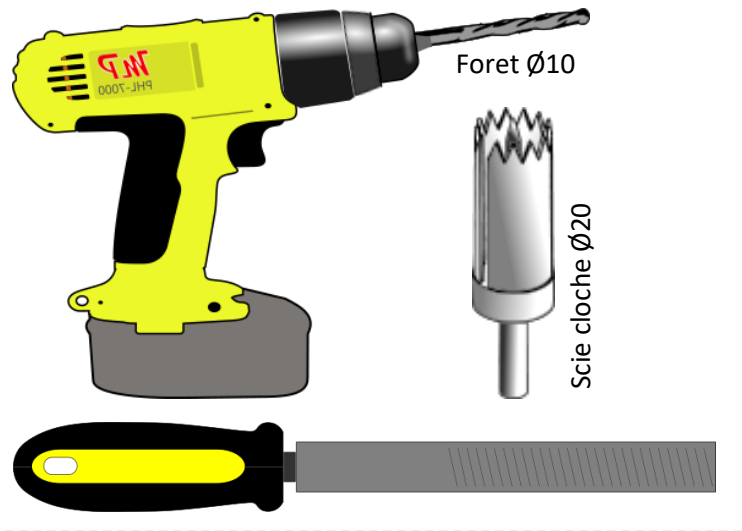

② ASSEMBLER LA SERRURE AVEC LA POIGNEE

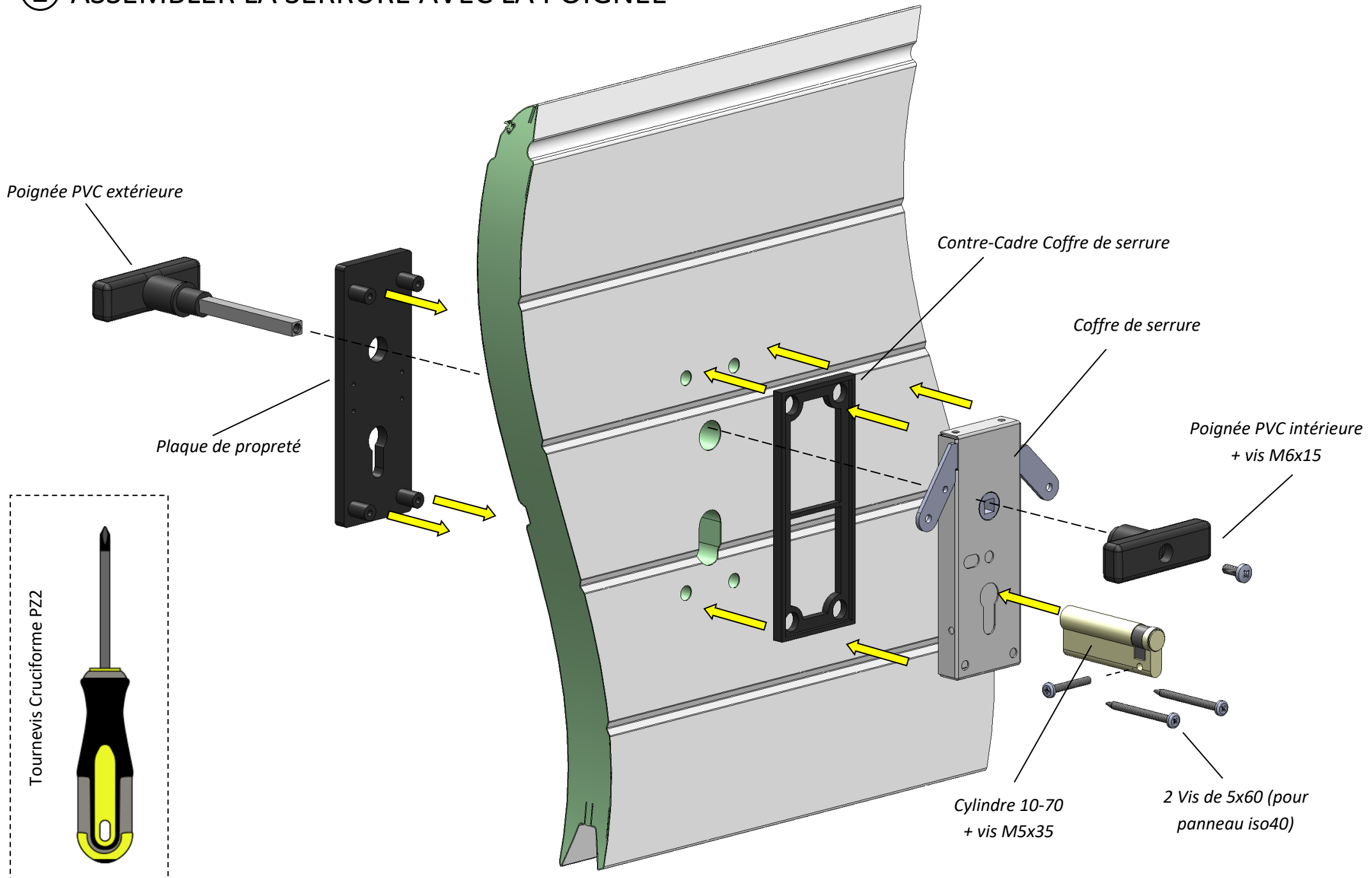

③ ASSEMBLER LES AUTOLATCH

Présenter et visser les autolatch au milieu de chaque bord du panneau (percer au $\varnothing 4$ si nécessaire)

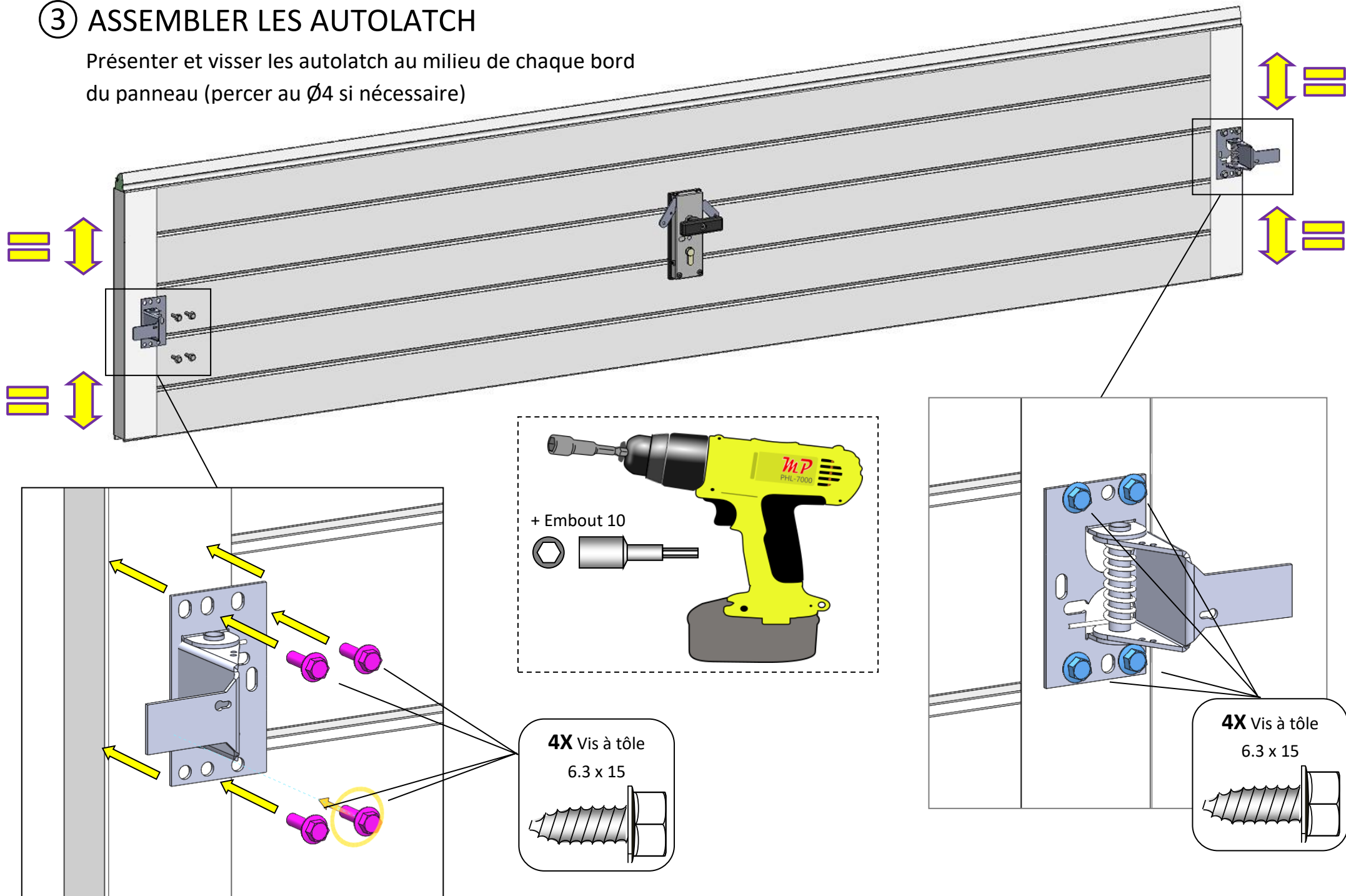

④ PREPARER LES CABLES

- ① Sertir au marteau 1 plomb à chaque extrémité du câble de 5m
- ② Couper le câble de 5 m en 2
- ③ Passer chacun des câbles dans les autolatch gauche et droit

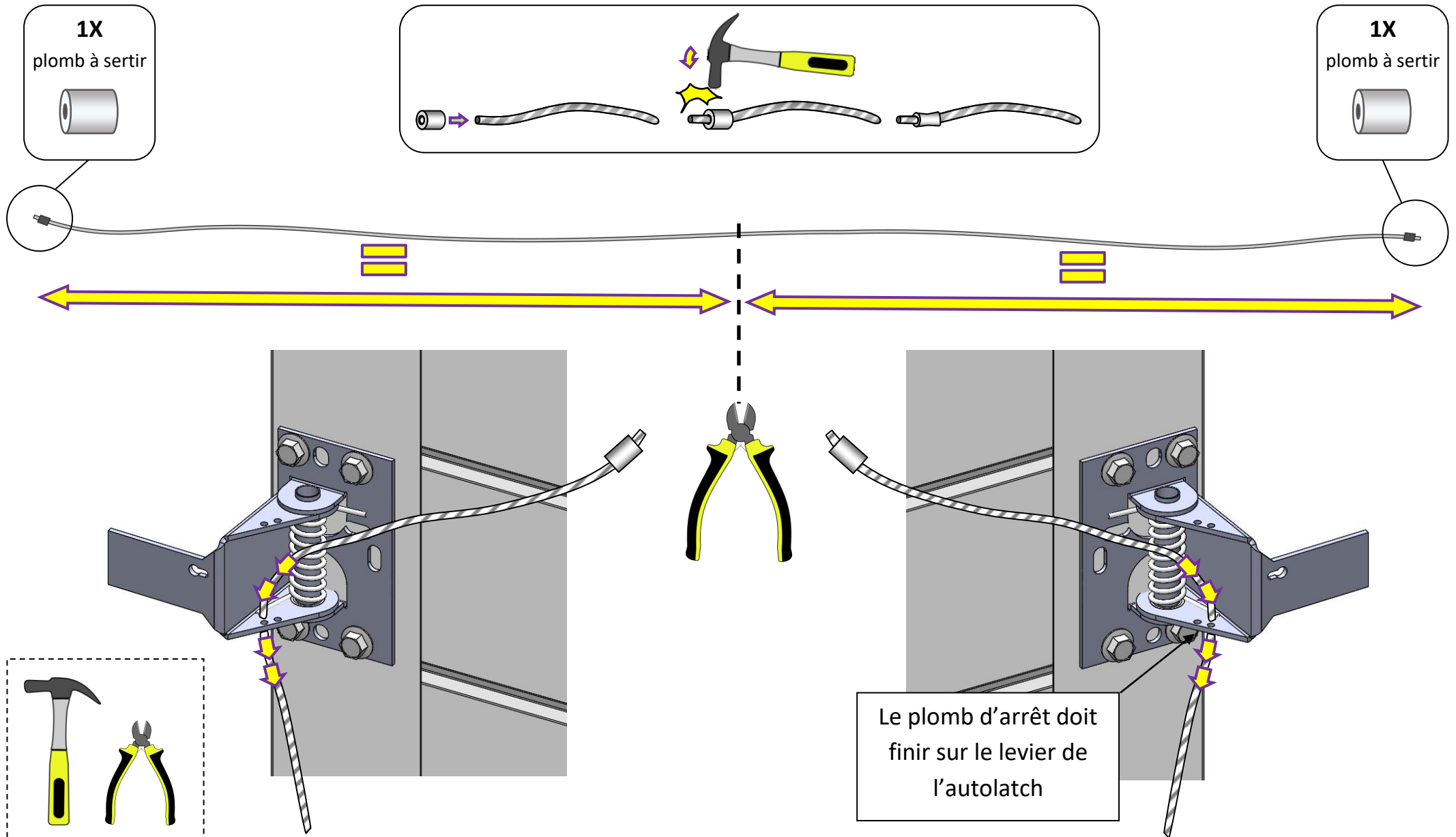

⑤ RELIER LES CABLES A LA SERRURE

- ① Tourner la poignée pour sortir les 2 sorties du coffre de serrure
- ② Relier les câbles aux 2 sorties du coffre central par une boucle
- ③ Refermer par 2 serre-câbles (ne pas serrer complètement)

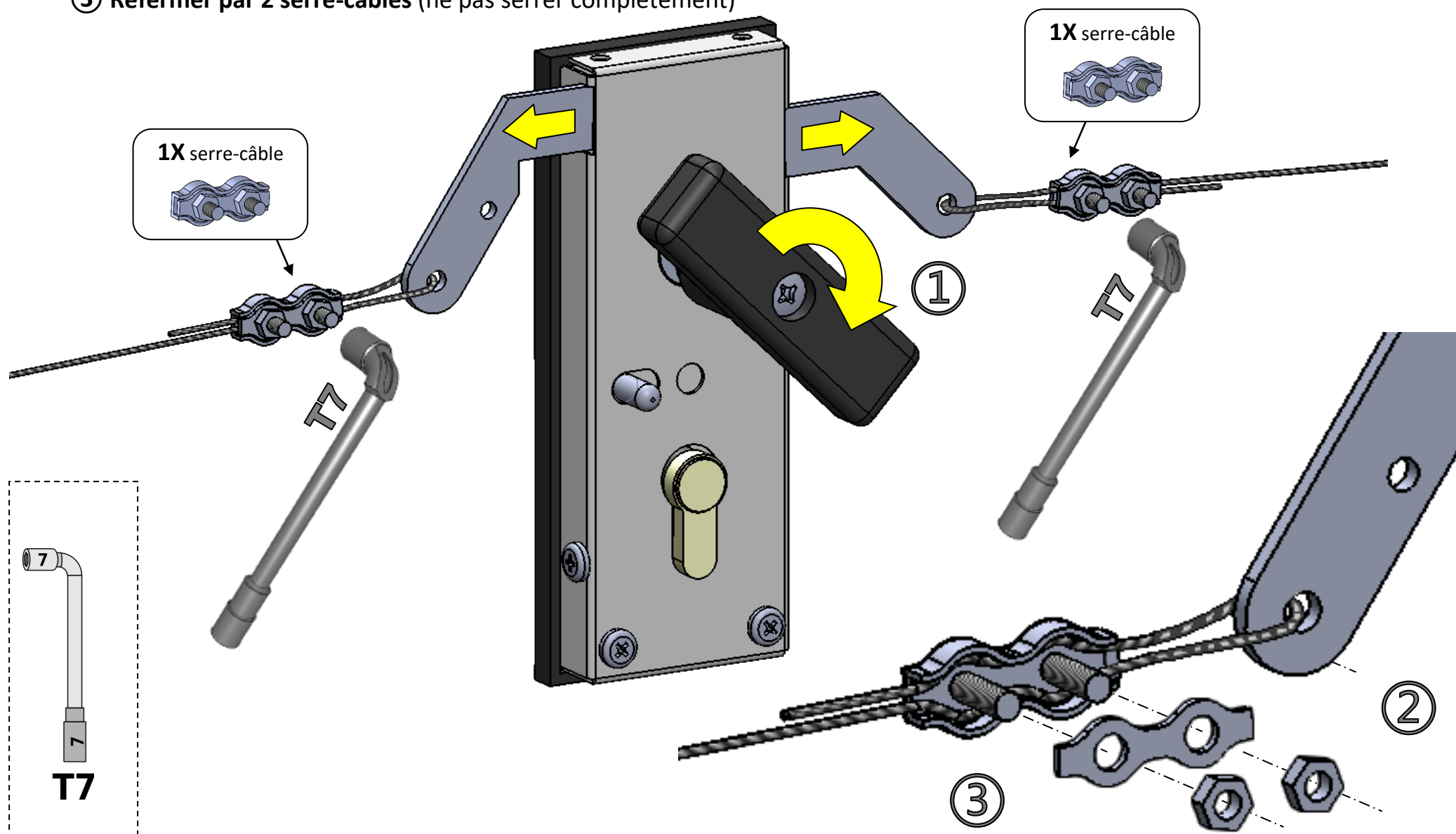

⑥ AJUSTER LA LONGUEUR DES CÂBLES

- ① **Ajuster la longueur des câbles** pour que, au repos les câbles soient tendus et que les autolatch soient légèrement écartés du rail de quelques mm
- ② **Serrer les 2 écrous** de 7 des serre-câbles
- ③ **Faire un test du fonctionnement** de la serrure en tournant la poignée, rajuster les câbles si besoin
- ④ Si le fonctionnement est correct, **couper les excédents de câble**

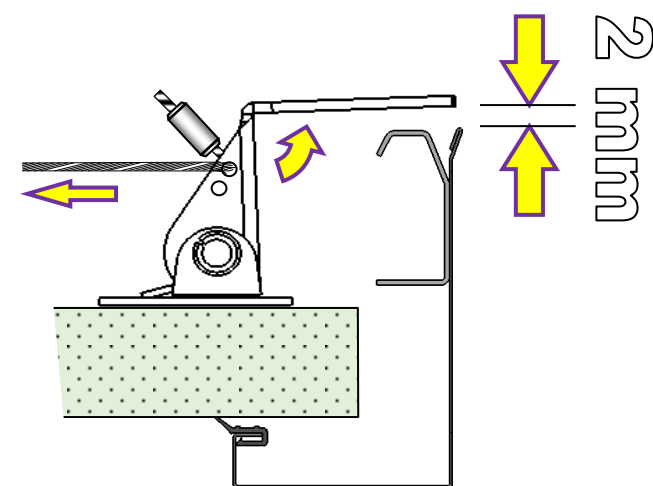
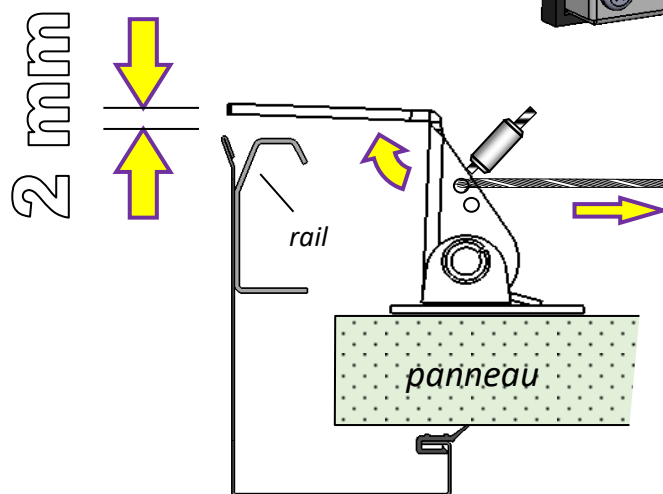
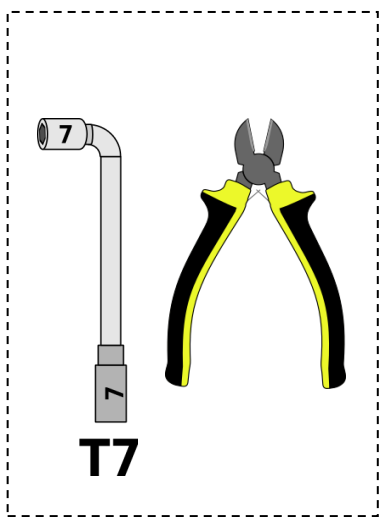
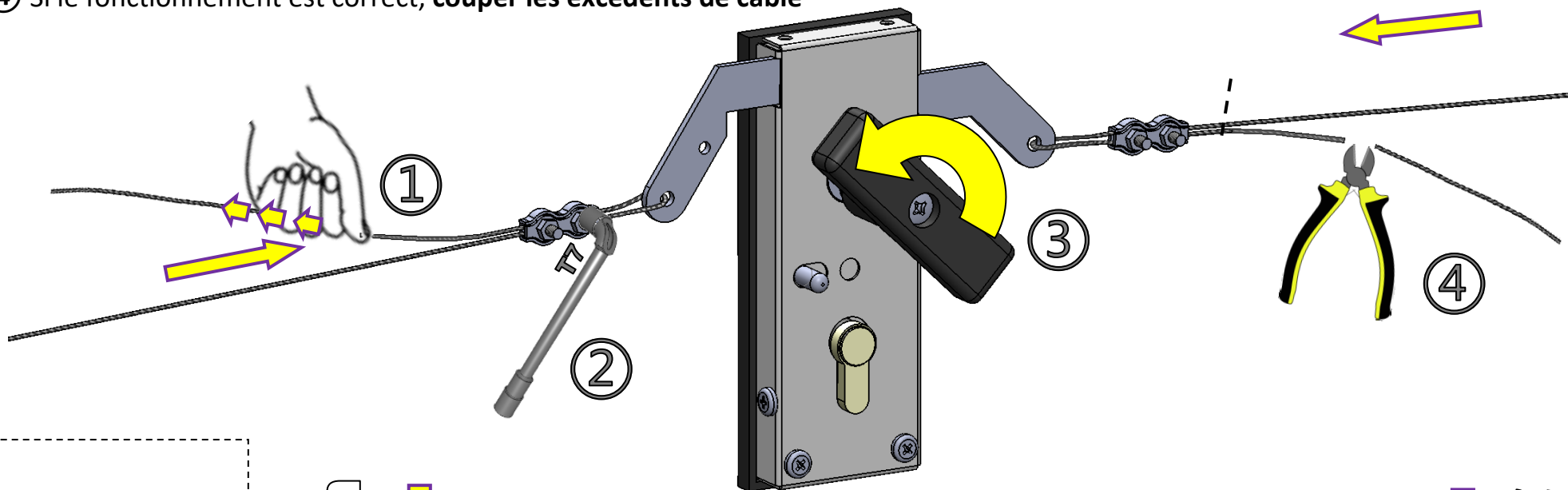

⑦ FIXER LES GACHES

- ① Porte bien fermée au sol, **placer les gâches en face des autolatch** (entre le rail et le profil de montant)
- ② **Tracer** la position des 2 trous de fixation
- ③ **Percer au Ø6**
- ④ **Fixer chacune des gâches avec 2 boulons M6**

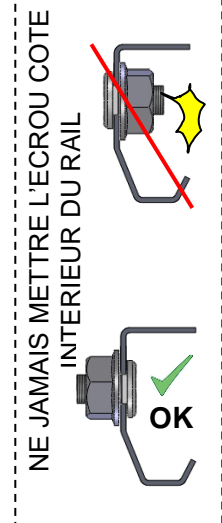
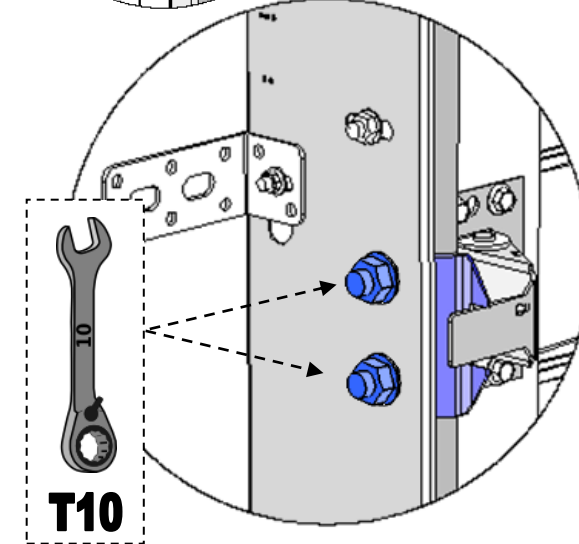
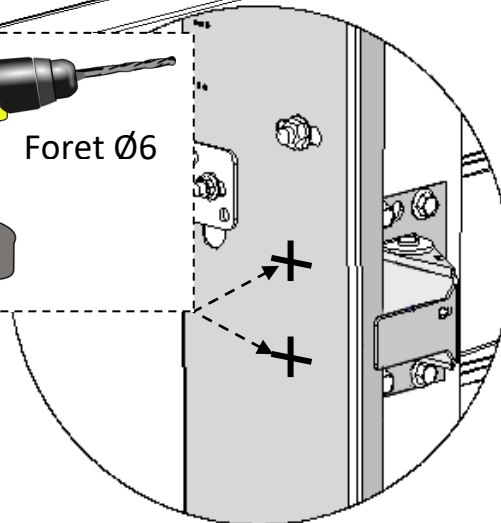
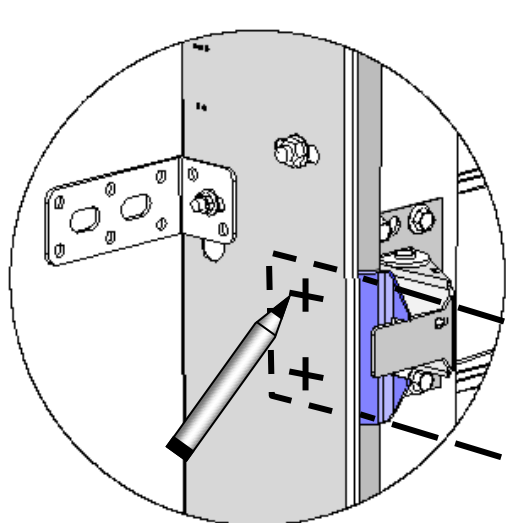
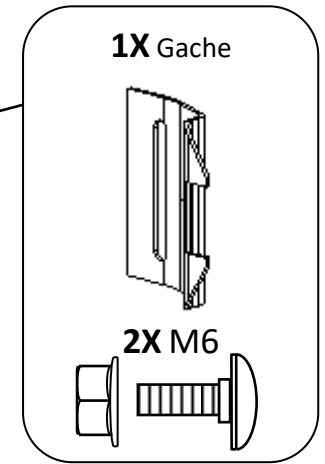
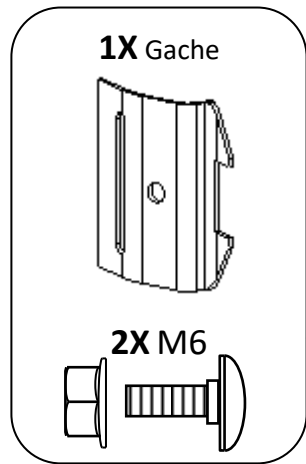
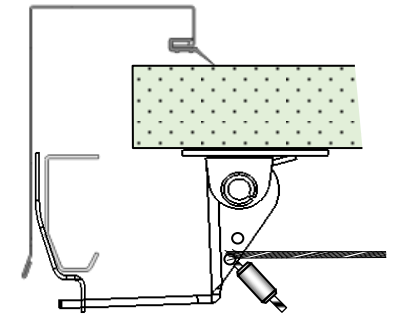

KIT SERRURE SECTIONNELLES 2 POINTS – VUE D'ENSEMBLE

